

APPLICATION OF MINIMUM CURVATURE METHOD TO WELLPATH CALCULATIONS

Richard Amarin

***Eric Broni-Bediako**

University of Mines and Technology, Tarkwa, Ghana

**E-mail: bronibediako2005@yahoo.co*

ABSTRACT

A major drawback of directional and horizontal well drilling is the numerous complex computations required to be done while planning a well. These computations are very stressful and time consuming especially when done manually. The aim of this study was to assess the application of minimum curvature method to wellpath calculations. Therefore this study developed a user friendly Excel Spreadsheet program that would make the computations of the well trajectory parameters easier, faster and accurate. An Excel Spreadsheet program was developed employing the Minimum Curvature method (and for other five methods) for wellpath design and planning. This would help increase the usage of these trajectory methods especially the Minimum Curvature method. The program was able to provide pictorial views both in the vertical and horizontal plane of the trajectory of the drilling bit's position in the wellbore. This would therefore help to minimize risk and uncertainty surrounding hitting predetermined target. This is possible because deviations can easily be detected and the necessary directional corrections or adjustment be initiated to re-orient the drilling bit to the right course before (planning process) and during the drilling operations.

Keywords: Complex computations, Excel Spreadsheet program, Minimum Curvature method

NOMENCLATURE

Symbol/Acronym	Description
$A_i, \varepsilon, \text{ or } \Phi$	Azimuth
BHA	Bottom Hole Assembly
BRT	Below Rotary Table
DFE	Derrick Floor Elevation
$D_i, D_{Mi}, \text{ TVD}$	True Vertical Distances
DOT	Downhole Orientation Tool
I, α_i, Θ	Inclination Angles
LA	Lead Angle
MWD	Measurement While Drilling
ND	North Displacement
R_i, r_i	Radius of Curvature
RKB	Rotary Kelly Bushing
STL	Survey Tool Length
TOD	Turn Off Depth
$X_i \text{ or MD}$	Measured Displacement
β, DL	Dogleg Severity Angle
$\Delta E, M_i$	Change in Easting
$\Delta N, L_i$	Change in Northing
ΔV	Change in Elevation

INTRODUCTION

Directional drilling is the science and art of deviating a wellbore along a planned course to a subsurface target whose location is a given lateral distance and direction from the vertical (Bourgoyne, Millheim, Chenvert, Young, 1991). Directional drilling and horizontal wells represent an efficient way to achieve or hitting special targets that may or are very difficult to reach using vertical wells (Tarek, 2000). Directional drilling is relatively done to increase production rates, control water and gas conning, control sand production and increase recovery rate (Bourgoyne et al, 1991). There are many reservoirs which cannot be tapped by vertical wells or would be uneconomical to exploit with vertical wells (Bourgoyne et al, 1991). Other reservoirs are also characterized by vertical permeability or the pay zones may be very thin and producing with vertical wells would require quiet a number of them which would make vertical wells to be very uneconomical in such situations. The application of vertical wells in such formations could also result in lower ultimate recovery (Tarek, 2000). In such low permeability formations, the only way out is to use directional and horizontal well technology which has over the years proved to enhance ultimate recovery (Bourgoyne et al, 1991). Due to the more economical nature of directional and horizontal wells over vertical wells in most cases, they are mostly the preferred technology in offshore drilling technology (Bourgoyne et al, 1991).

A major drawback of directional and horizontal well drilling is the numerous complex computations required to be done ahead of time before drilling resumes and also during drilling operations (Sawaryn, 2005). These computations become very stressful and more complex when done manually. The programs available in the market used for these computations are usually very expensive to acquire, but the development of a user-friendly Excel Spreadsheet program which employs the Minimum Curvature method for wellpath planning would help minimize the stress and time in executing these complex computations. More importantly, an Excel Spreadsheet program is very flexible and can easily be modified or updated at any point in time to meet the needs of the industry.

The objectives of this study are: (i) to develop a user friendly Excel Spreadsheet program that will make the computations of well trajectory parameters easier, faster and accurate, and (ii) use the Excel Spreadsheet program to evaluate and compare some of the survey calculation method available for the industry. These methods are the Tangential, Averaging Angle, Balanced Tangential, Mercury, Radius of Curvature and the Minimum Curvature methods.

Directional wells are drilled with intentional control to hit a pre-determined target with the aid of controlling inclination (angle) and azimuth (direction). Directional drilling is drilling in three dimensions (3-D) (Bourgoyne et al, 1991). Directional drilling has proven technically and economically feasible in a broad range of geologic settings, including tight gas, heavy oil, and coalbed methane (Molvar, 2003). This method is proven to substantially increase producible reserves of oil and gas. Because the increased productivity of directional drilling compensates for additional costs, directional drilling is often more profitable than vertical drilling (Molvar, 2003). Some of the reasons for or applications of directional drilling are listed below; (Bourgoyne et al, 1991, Osisanya, 2009).

- (a) For Economics/Environmental Issues
- (b) To drill multiple wells from artificial structures, field development offshore in deep waters or remote locations
- (c) To sidetrack any obstruction ('junk') in the original wellbore
- (d) To explore for additional producing horizons in adjacent sectors of the field
- (e) To re-drill well
- (f) To put out fire resulting from blowout (relief wells)
- (g) To drill to reservoirs avoiding inaccessible locations
- (h) For Salt Dome drilling
- (i) For Fault controlling

Fundamental Concepts and Basis of Directional Drilling

For any directional drilling, three components are measured at any given point in the wellbore in order to determine its position. The technique of measurement of these three components is termed a survey. The depth, drift angle (inclination) and azimuth are measured (Osisanya, 2009). There are over eighteen methods available for calculating or determining the trajectory of a wellbore (Bourgoyne et al, 1991). The main difference in all the techniques is that one group uses straight lines approximations and the other assumes the wellbore is more of a curve and is approximated with curved segments. Listed in table 1.0 are comparisons of six of the methods in ascending order of preference and also complexity of techniques;

Table 1: Comparison of accuracy of the six methods (Bourgoyne et al, 1991)

Method	TVD	Diff. From Actual (ft)	North Displacement	Diff. From Actual (ft)
Tangential	1628.61	-25.38	998.02	43.09
Balanced Tangential	1653.61	-0.38	954.72	-0.21
Mercury	1653.62	-0.37	954.89	0.04
Angle -Averaging	1654.18	0.19	955.04	0.11
Radius of Curvature	1653.99	0	954.93	0
Minimum Curvature	1653.99	0	954.93	0

The tangential method shows considerable error for the northing, easting and elevation which makes it no longer preferred in the industry (Bourgoyne et al, 1991). The differences among the average angle, balanced tangential, radius of curvature and minimum curvature are very small and any of the methods could be used for calculating the trajectory. Because the Minimum Curvature method is the most widely preferred method in the oil industry, more emphasis would be laid on in the next section than the other methods. The Tangential, Balanced Tangential, Mercury and Angle averaging, are applicable to wellbore trajectory which follows straight line course whiles the Radius of Curvature is strictly applicable to a wellbore trajectory that follows a curved segment. The Minimum Curvature method is applicable to any trajectory path.

THE MINIMUM CURVATURE METHOD

In all the Minimum Curvature methods, two adjacent survey points are assumed to lie on a circular arc. This arc is located in a plane and the orientation of which is defined by known inclination and direction angles at the ends of the arc (Bourgoyne et al, 1991). In 1985, the Minimum Curvature method was recognized by

the industry as one of the most accurate methods, but was regarded as cumbersome for hand calculation. The emergence of well-trajectory planning packages to help manage directional work in dense well clusters increased its popularity. With the application of the Minimum Curvature method, toolface, interpolation, intersection with a target plane, minimum and maximum true vertical depth (TVD) in a horizontal section, point closest to a circular arc, survey station to a target position with and without the direction defined, nudges, and steering runs can be determined (Sawaryn, 2005).

PROGRAM DEVELOPMENT IN EXCEL SPREADSHEET

The data input interface in the Excel Spreadsheet contains three sections which are;

- 1 The Well description Input Data section requires the input of description data such as Company Name, Field Name, Well Name, Reservoirs/Fluid type and name of the Drilling Engineer in charge of operations.
- 2 The Adjustment/Correction Input section requires the input of adjustment or correctional data values such as the Lead Angle and or The Magnetic Declination adjustment value(s). These values are needed for the adjustment of the spatial data. The lead and magnetic declination angles must be in degrees. The directions for both the lead and magnetic declination angle must be specified. If the bit walk is to the right, the word 'Right' should be selected from the drop-down menu otherwise the word 'Left' should be selected for left walk of bit to make the necessary adjustments. The same approach is applicable to the magnetic declination adjustment. If the magnetic declination is to the West, the word 'West' must be selected otherwise the 'East' should be selected for East magnetic declination.

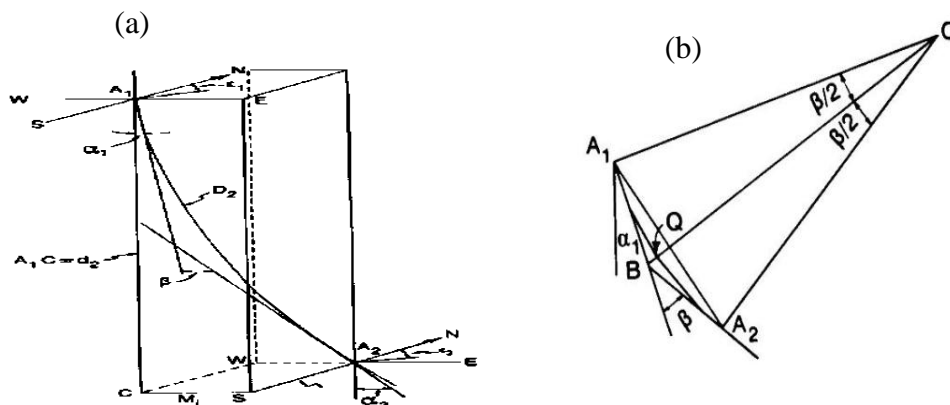

Figure 1(a): A representation of the geometry of the Minimum Curvature method
 (b): A representation of the Minimum Curvature ratio factor (RF) (Bourgoyne et al, 1991).

Where in figure 1, β is the dogleg severity, ϵ is the azimuth, α is the inclination angle. The doglegs in directional holes bend the casing and induce added axial stress (Chukwu, 2008). Except for large casings this is not critical for most loads actually encountered when designing for this effect on tension (Chukwu, 2008). This is essentially the Balanced Tangential Method, with each result multiplied by a ratio factor (RF) as follows:

$$\Delta E = \Delta MD / 2 [\sin I_1 \sin A_1 + \sin I_2 \sin A_2] RF \dots\dots\dots 1$$

$$\Delta N = \Delta MD / 2 [\sin I_1 \cos A_1 + \sin I_2 \cos A_2] RF \dots\dots\dots 2$$

$$\Delta V = \Delta MD / 2 [\cos I_1 + \cos I_2] RF \dots\dots 3$$

RF can be derived from Figure 1.0 (b) as follows;

The straight line segments A₁B + BA₂ adjoin the segment A₁Q + QA₂ at points A₁ and A₂. It can then be shown that

$$A_1Q = OA_1 \cdot \beta / 2 \dots\dots\dots 4$$

$$QA_2 = OA_2 \cdot \beta / 2 \dots\dots\dots 5$$

$$A_1B = OA_1 \cdot \tan(\beta / 2) \dots\dots\dots 6$$

$$BA_2 = OA_2 \cdot \tan(\beta / 2) \dots\dots\dots 7$$

The ratio of dividing the straight line section (eqns 6 and 7) with the curved section (eqns 4 and 5) respectively, defines the ratio factor, RF

$$RF = A_1 \cdot \tan\left(\frac{\beta}{2}\right) \dots\dots\dots 7$$

$$RF = A_1B / A_1Q = BA_2 / QA_2 = \tan(\beta / 2) / \beta / 2 \dots\dots\dots 8$$

$$RF = A_1B / A_1Q = BA_2 / QA_2 = \tan(\beta / 2) / \beta / 2 \dots\dots\dots 9$$

$$RF = 2 / \beta_i \tan(\beta_i / 2) \dots\dots\dots 10$$

Where the dogleg angle β is the overall angle change of the drill pipe between any two stations is computed as;

$$\beta_i = \cos^{-1} [\cos(I_2 - I_1) - \sin I_1 \sin I_2 [1 - \cos(A_2 - A_1)]] \dots\dots\dots 11$$

or

$$\beta = \cos^{-1} [\cos I_1 \cos I_2 + \sin I_1 \sin I_2 \cos(A_2 - A_1)] \dots\dots\dots 12$$

The condition of applying this ratio factor is that if the dogleg angle is less than 0.25 radians, then it reasonable to set the ratio factor to one (1) else the computation holds (Bourgoyne et al, 1991) This is usually done to avoid singularity in straight hole. If the β is approximately less than 15°, then the resultant error will be less than 1 part in 10⁹ (BP Amoco, 1999). The RF can also be calculated using equations if the dogleg angle is less than approximately 15°, this is a truncated series expansion given by the form (BP Amoco, 1999)

$$RF = 1 + \beta^2 / 12 + \beta^4 / 120 + 17\beta^6 / 20160 \dots\dots\dots 13$$

Once the β and RF are determined, the spatial coordinates (easting, northing and elevation coordinates) can be computed.

Tables 1 and 2 summarize all the equations that were used to generate the excel spreadsheet program to compute the wellpath trajectory coordinates employing the six different methods listed above.

Table 2: Summary of equations used to generate the excel spreadsheet program

Method	Equations
Tangential	<ol style="list-style-type: none"> 1. $\Delta E = \Delta MD \sin(I_2) \sin(A_2)$ 2. $\Delta N = \Delta MD \sin(I_2) \cos(A_2)$ 3. $\Delta V = \Delta MD \cos(I_2)$
Balanced Tangential	<ol style="list-style-type: none"> 1. $\Delta E = \frac{\Delta MD}{2} [\sin I_1 \sin A_1 + \sin I_2 \sin A_2]$ 2. $\Delta N = \frac{\Delta MD}{2} [\sin I_1 \cos A_1 + \sin I_2 \cos A_2]$ 3. $\Delta V = \frac{\Delta MD}{2} [\cos I_1 + \cos I_2]$
Mercury	<ol style="list-style-type: none"> 1. $\Delta E = \left[\frac{\Delta MD - STL}{2} \right] [\sin I_1 \sin A_1 + \sin I_2 \sin A_2] + (STL) \sin I_2 \sin A_2$ 2. $\Delta N = \left[\frac{\Delta MD - STL}{2} \right] [\sin I_1 \cos A_1 + \sin I_2 \cos A_2] + (STL) \sin I_2 \cos A_2$ 3. $\Delta V = \left[\frac{\Delta MD - STL}{2} \right] [\cos I_1 + \cos I_2] + (STL) \cos I_2$
Angle Averaging	<ol style="list-style-type: none"> 1. $\Delta E = \Delta MD \sin(I_{Avg}) \sin(A_{Avg})$ 2. $\Delta N = \Delta MD \sin(I_{Avg}) \cos(A_{Avg})$ 3. $\Delta V = \Delta MD \cos(I_{Avg})$
Radius of Curvature	<ol style="list-style-type: none"> 1. $\Delta E = \frac{\Delta MD (\cos I_1 - \cos I_2) (\cos A_1 - \cos A_2)}{[(I_2 - I_1)(A_2 - A_1)]}$ 2. $\Delta N = \frac{\Delta MD (\cos I_1 - \cos I_2) (\sin A_2 - \sin A_1)}{[(I_2 - I_1)(A_2 - A_1)]}$ 3. $\Delta V = \frac{\Delta MD (\sin I_2 - \sin I_1)}{(I_2 - I_1)}$
Minimum Curvature	<ol style="list-style-type: none"> 1. $\Delta E = \frac{\Delta MD}{2} [\sin I_1 \sin A_1 + \sin I_2 \sin A_2] RF$ 2. $\Delta N = \frac{\Delta MD}{2} [\sin I_1 \cos A_1 + \sin I_2 \cos A_2] RF$ 3. $\Delta V = \frac{\Delta MD}{2} [\cos I_1 + \cos I_2] RF$ <p>Where</p> $RF = 2/\beta_i \tan(\beta_i/2) \text{ and}$ $\beta_i = \cos^{-1} [\cos(I_2 - I_1) - \sin I_1 \sin I_2 [1 - \cos(A_2 - A_1)]]$

Table 3: Equations for Special cases for the Radius of Curvature method

Special Case	Radius of Curvature method
Case 1 , if $I_1 = I_2$	<ol style="list-style-type: none"> 1. $\Delta E = \frac{\Delta MD \sin I_1 (\cos A_1 - \cos A_2)}{[(A_2 - A_1)]}$ 2. $\Delta N = \frac{\Delta MD \sin I_1 (\sin A_2 - \sin A_1)}{[(A_2 - A_1)]}$ 3. $\Delta V = \Delta MD \cos I_1$
Case 2 if and $A_1 = A_1$	<ol style="list-style-type: none"> 1. $\Delta E = \frac{\Delta MD \sin A_1 (\cos I_1 - \cos I_2)}{[(I_2 - I_1)]}$ 2. $\Delta N = \frac{\Delta MD \cos A_1 (\cos I_1 - \cos I_2)}{[(I_2 - I_1)]}$ 3. $\Delta V = \frac{\Delta MD (\sin I_2 - \sin I_1)}{[(I_2 - I_1)]}$
Case 3, if $I_1 = I_2$ and $A_1 = A_1$	<ol style="list-style-type: none"> 1. $\Delta E = \Delta MD (\sin I_1 \sin A_1)$ 2. $\Delta N = \Delta MD (\sin I_1 \cos A_1)$ 3. $\Delta V = \Delta MD (\cos I_1)$

VALIDATION OF THE EXCEL SPREADSHEET PROGRAM

Two sets data from the secondary source were used in validating the excel spreadsheet program. The first was the data used by Adams (1985) and the second was from Bourgoyne et al (1991). Adams (1985) used an Adams and Rountree computer program in his trajectory computations. The input data used in the validation are shown on tables A and B in appendix. Tables 3 and 4 show a comparative wellbore trajectory results summary from the excel spreadsheet program using the Adams, (1985) and Bourgoyne data.

Table 4: A Comparative Wellbore Trajectory Results Summary from the Excel Spreadsheet Program using the Adams (1985) Data

Trajectory Methods	True Vertical Depth (ft)	Difference from Actual (ft)	Total Displacement	Difference from Actual (ft)
Tangential	1582.12	62.86	1829.87	69.45
Balanced Tangential	1518.42	-0.84	1759.41	-1.01
Angle-Averaging	1,535.59	16.33	1776.82	16.40
Radius of Curvature	1530.00	10.74	1771.47	11.05
Minimum Curvature	1519.26	0.00	1760.42	0.00
Mercury	1518.42	-0.84	1759.41	-1.01

Table 5: A Comparative Wellbore Trajectory Results Summary between the Bourgoyne et al (1991) and the Excel Spreadsheet Program

Trajectory Methods	True Vertical Depth (TVD) (ft)		Difference from Actual (TVD) (ft)		North Displacement (ND) (ft)		Difference from Actual (ND) (ft)	
	Bourg.	Excel	Bourg.	Excel	Bourg.	Excel	Bourg.	Excel
Tangential	1,628.61	1628.61	-25.38	-25.38	998.02	998.01	43.09	43.08
Balanced Tangential	1,653.61	1653.61	-0.38	-0.38	954.72	954.71	-0.21	-0.22
Angle-Averaging	1,654.18	1654.18	0.19	0.19	955.04	955.04	0.11	0.11
Radius of Curvature	1,653.99	1653.99	0.00	0.00	954.93	954.93	0	0.00
Minimum Curvature	1,653.99	1653.99	0.00	0.00	954.93	954.93	0	0.00
Mercury	1,153.62	1649.86	-0.37	-4.13	954.89	961.21	0.04	6.28

Figures 1 and 2 show a zoomed vertical and horizontal plots of the Excel Spreadsheet Program results using Bourgoyne data respectively.

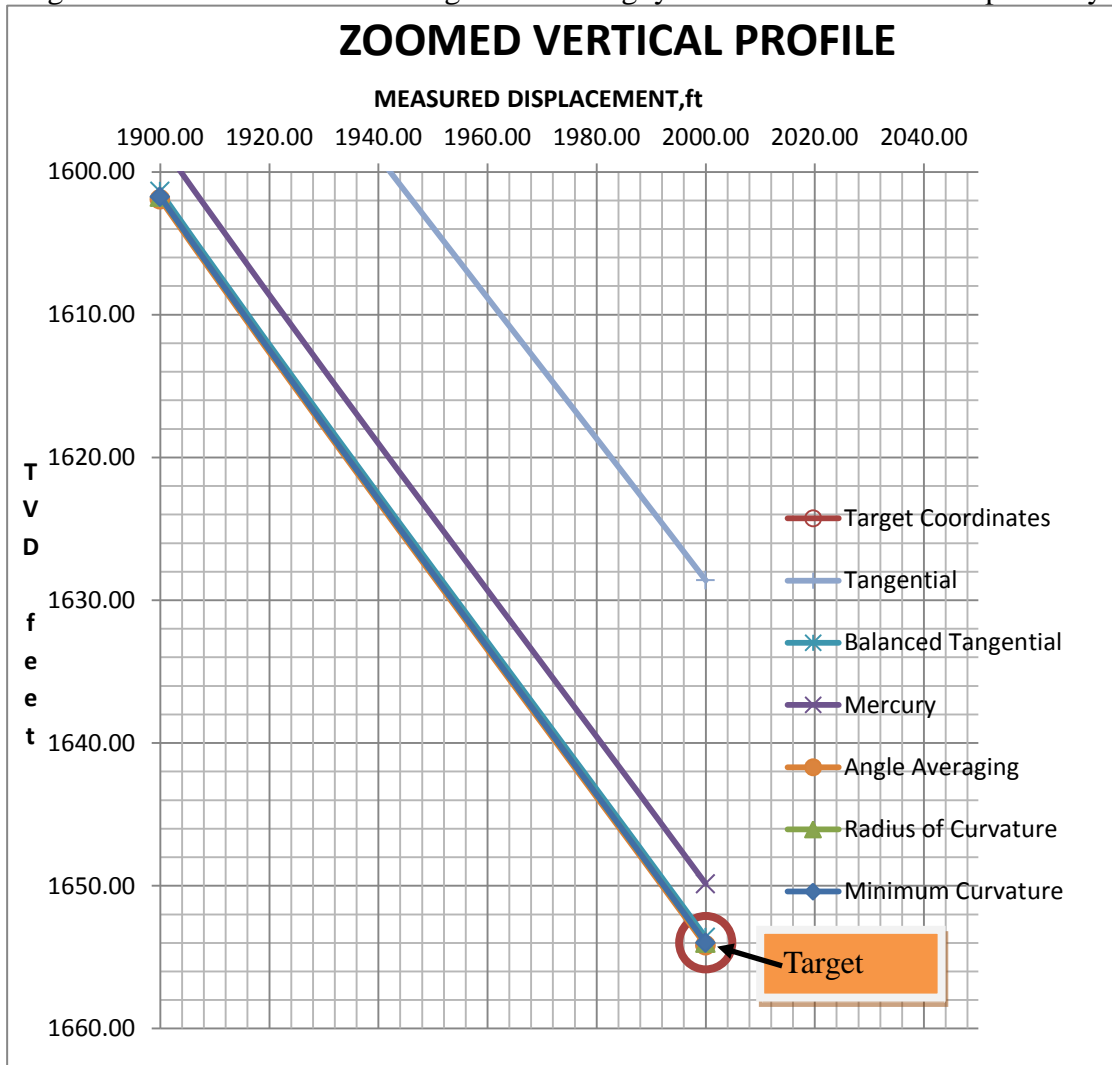

Figure 1: A zoomed vertical plot of the Excel Spreadsheet Program results using Bourgoyne data

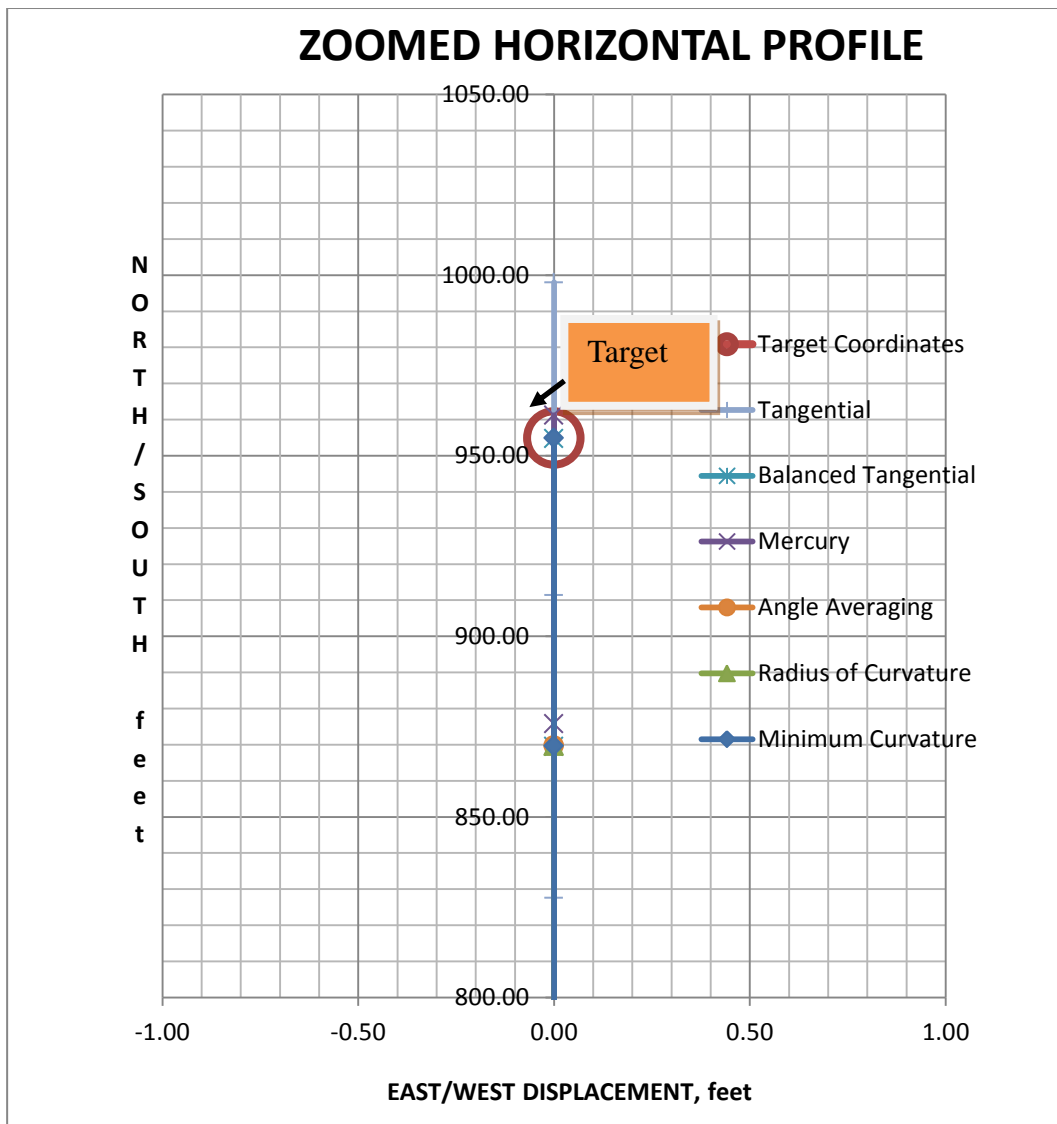

Figure 2: A zoomed horizontal plot of the Excel Spreadsheet Program results using Bourgoyne data

The advantages of using the Excel Spreadsheet compared to other available commercial software packages are that;

- The Excel Spreadsheet program is cheaper
- It is also user-friendly (friendly data input interfaces)
- It is faster since it consumes lesser computer memory
- It can be easily modified to suit the needs of any individual operator
- Produces the same results as the ones obtained from the commercial software packages.

CONCLUDING REMARK

A user friendly Excel Spreadsheet program was developed that incorporated the Tangential, Angle Averaging, Balanced Tangential, Mercury, Radius of Curvature and the Minimum Curvature methods for the computation of well trajectory from survey data. The developed user-friendly Excel Spreadsheet was validated using two data from the literature. Results obtained were fairly the same as obtained and very accurate. The program provides pictorial views both in the vertical and horizontal plane of the trajectory position of the drilling bit in the wellbore. These help to minimize risk and uncertainty surrounding hitting predetermined target since deviations can easily be detected and the necessary directional corrections or adjustment initiated with less ease. The program computes the position at each survey station and therefore be able to predict the length and direction from a survey station relative to the target position. The differences in results obtained using the average angle, balanced tangential, mercury, radius of curvature and minimum curvature method are very small hence any of the methods can be used for calculating the well trajectory. The sensitivity of deviation from hitting a target of each of the methods may differ for different operators. This may also be related to the area extent of the target and that the accuracy of each method is very relative. The program should be constantly up-dated/graded to fully meet the dynamic requirements of the industry should the need be. The Minimum Curvature Method should be embedded in survey calculations to enhance accuracy during planning process. From this study the Minimum Curvature method is the best method recommended for the calculating wellbore calculations paths because it is applicable to any trajectory path. This method is particularly useful when planning trajectory paths for drilling relief wells.

REFERENCES

- Adams J. Neal and Charrier Tommie, *Drilling Engineering, A Complete Well Planning Approach*, PennWell Publishing Company, Tulsa, Oklahoma, 1985, pp. 342, 345.
- Bourgoyne, Millheim, Chenvert, Young: *Applied Drilling Engineering*, SPE Textbook Series, Vol. 2, 1991, pp 351-366.
- Chukwu A. Godwin, *Drilling and Well Completion Lecture material*, African University of Science and Technology, Abuja-Nigeria, 2008, pp 257.
- Molvar E.M., 2003. *Drilling smarter: Using minimum-footprint directional drilling to reduce oil and gas impacts in the Intermountain West*. Laramie, WY: Biodiversity Conservation Alliance, 32 pp, 2003.
- Osisanya O. Samuel, *Advanced Drilling Engineering Lecture Material*, African University of Science and Technology, Abuja-Nigeria, Spring 2009, pp 276-279,
- Sawaryn S.J., SPE, and J.L. Thorogood, "A Compendium of Directional Calculations Based on the Minimum Curvature Method", SPE 84246-PA, 2005, 1st presented at the 2003 SPE Annual Technical Conference and Exhibition, Denver. Colorado.
- Tarek Ahmed, *Reservoir Engineering Handbook*, Second Edition, Gulf Publishing Company, Houston, Texas, 2000, pp 515, 615.

APPENDIX

A. Data Input Interface

The use of magnetic compass in bearing reading requires a magnetic declination correction or adjustment to be effected to the reading for attaining the correct azimuth which is a requisite to the computation of the wellbore coordinates. The directions for the lead angle must also be specified. If the bit walk and magnetic declination adjustment are specified, the necessary computations could then be done. The true azimuth computation (corrected for azimuth and lead angle) is given by;

$$\phi^{\circ} = \phi^{\circ}(\text{read}) \pm \text{Magnetic Declination Angle} \pm \text{Lead Angle} \dots\dots\dots AI$$

The signs of the corrections are determined by the direction of the magnetic declination and the lead angle. Thus, if the lead angle is to the right, the correction is negative otherwise it is positive. Also, if the magnetic declination is to westward, the sign is negative otherwise it is positive.

The target, initial or starting coordinates may be entered if needed, or else, zeros must be entered as the starting and or the same for the target coordinates. The unit of measurement of the coordinates or measured distances must be selected under the 'units'. The word 'Feet' must be selected for units in feet.

The final data needed to be entered are the Measured distances (MD), Inclination angles (I) and Measure Bearings (A) with their corresponding descriptive data such as the station ID. Both the inclination and azimuth angles must be entered in degrees. The whole circle bearing reading approached must be adhered to when entering the azimuth angles. The general interface of the excel spreadsheet data input section is shown in figure B.

Company	AmoBron		
Field	G21		
Well	7A		
Reservoir/Fluid Type	Light Oil		
Engineer	Amorin Richard		
Date	Monday, 31 August 2009		

Bit Walk Direction
Select the word 'Right' for right bit-walk or 'Left' for left bit-walk

Lead Angle (Bit Walk)	ϕ° 0.00	Bit walk Right
Magnetic Declination Adjustment Value	ϕ° 0.00	Magnetic Declination East

Select (Right) for right bit-walk or (Left) for Left bit-walk

Select (West) for west declination or (East) for East Declination

Target Coordinates	Feet	Units of Measurement
Station ID	Chem1	
Northing	954.930	
Easting	0.000	Feet
Elevation	1653.987	
MD	2000.000	

Select (Feet) for units in feet or (Metre) for units in metres

Starting/Initial Coordinates	Feet	Units of Measurement
Station ID	Bron 7	
Northing	0.000	
Easting	0.000	Feet
Elevation	0.000	
Survey Tool Length (STL)	15.000	For Mercury Method

Select (Feet) for units in feet or (Metre) for units in metres

Station ID	Measured distance MD	Inclination θ° (I)	Azimuth ϕ° (A)
KOP	0.00	0.00	0
1	100.00	3.00	0
2	200.00	6.00	0
3	300.00	9.00	0
4	400.00	12.00	0
5	500.00	15.00	0
6	600.00	18.00	0
7	700.00	21.00	0
8	800.00	24.00	0
9	900.00	27.00	0
10	1000.00	30.00	0
11	1100.00	33.00	0
12	1200.00	36.00	0
13	1300.00	39.00	0
14	1400.00	42.00	0
15	1500.00	45.00	0
16	1600.00	48.00	0
17	1700.00	51.00	0
18	1800.00	54.00	0
19	1900.00	57.00	0
20	2000.00	60.00	0

Enter only Whole Circle Reading bearings Values

Figure B. - A General Interface of the Excel Spreadsheet Data Input Section.

Table A: Survey Data Obtained from Adams, (1985)

Measured Depth, (ft)	Hole Angle (°)	Azimuth (°)
3,000	2	N28E
3,300	4	N10E
3,600	8	N35E
3,900	12	N25E
5,000	15	N30E
6,000	16	N28E
7,000	17	N50E
8,000	17	N20E
9,000	17	N30E
10,000	17	N25E

Table B: Survey Data and Summary of Computed Wellbore Trajectory Results Obtained from Bourgoyne et al, (1991).

Direction:	Due North			
Survey Interval:	100 ft			
Rate of build:	3°/100 ft			
Total Inclination:	60° at 2,000 ft			
	Total Vertical Depth		North Displacement	
	Difference From		Difference From	
<u>Calculation Method</u>	<u>Actual (ft)</u>		<u>Actual (ft)</u>	
Tangential	1,628.61	-25.4	998.02	43.09
Balanced Tangential	1,653.61	-0.38	954.72	-0.21
Angle Averaging	1,654.18	0.19	955.04	0.11
Radius of Curvature	1,653.99	0	954.93	0
Minimum Curvature	1,653.99	0	954.93	0
Mercury*	1,153.62	-0.37	954.89	0.04

***A fifteen foot survey tool was used for the computation of the Mercury Method.**