

# THE DEVELOPMENT OF A GENERAL PURPOSE OPTICAL COUNTING DEVICE

**Olatunbosun, A.**

**Akarakiri, O. O.**

*Department of Electrical Engineering  
Faculty of Technology  
University Ibadan, Ibadan - Nigeria*

## ABSTRACT

*Accurate determination of the number of occurrence of a particular event is of significance in the field of science and engineering and to some extent, in the field of the social sciences. This experiment was on the development of an optical counting device that can be used in the determination of the number of occurrence of an event in any of these fields. The device is based on sensing the obstruction of light intensity by the object(s) to be counted and has facility for storing and displaying the total number of occurrence of the event(s).*

**Keywords:** *Science, Engineering, optical counting device, number*

## INTRODUCTION

Determination of the number of occurrence of an event over a certain period of time is a common phenomenon in many human endeavours. This includes the determination of the number of goods or product being rolled out on a conveyor line, number of people, entering a restricted area for example, stadium, parks, etc. Others include the determination of the distance covered by a moving vehicle and the number of bagged/bottled product produced in process/manufacturing industries. There are many methods by which counting of discrete events can be carried out, each event probably having a few devices that best suits it. These devices could be mechanical, electromechanical, optical or based on infra-Red or ultrasonic beams.

The electromechanical devices normally have a mechanical primary device (sensor) which detects the occurrence of the event under consideration, the rest of the device being electronic in nature and are used for conditioning and processing the signal from the sensor. The sensors include magnetic reeds, metallic contacts, make and break switches, bellows, relays etc. (Stephen, 1970). Mechanical counting devices are wholly mechanical in nature. Examples are the tally counter, odometer and the rotary counter. The rotary counter has horizontal bars which are moved an angular distance by the objects being counted. The angular movement of each bar causes the mechanism of the rotary counter to move the display digit, a discrete step to indicate the new count. The digits of the displays are written already on the edges of some rings through which a rod passes. The rings are equipped with a mechanism that generates a "carry signal" from a lower ring to an upper one any time the former goes from 0 to 9 and back to 0. The carry mechanism causes the higher ring to move and display the next higher digit on it.

Ultrasonic and infra-red counting devices basically have ultrasonic or infra-red sensing elements and an electronic signal processing and display parts (Douglas, 1979). An optical counting device makes use of a photo sensitive device as its input device and just as in the ultrasonic and infra-red devices; it also requires a transmitter/receiver pair. The transmitter is basically a light source and the receiver, a light sensitive device. The simplicity of the optical counter with no requirement for high level of accuracy in the counting of discrete events makes the device an appropriate one for most counting applications. Also, the cost of the optical counting elements and the ready availability of most of the components involved in its development give an edge over the other devices. The circuitry of the device is much simpler than that of an equivalent infra-red or ultrasonic counting device. For instance, an ultrasonic based counting device requires an ultrasonic frequency generator as its transmitter, while a simple light bulb or even the natural day light is all that is needed for the transmitter in the transmitter in the case of an optical device.

### **DESCRIPTION OF THE OPTICAL COUNTING DEVICE (OCD)**

**Counting Operation of the OCD:** The OCD achieves its counting operation through the detection of the obstruction of the light intensity incident on it by the event being counted. For every obstruction, an electrical pulse is generated by the event counter and the new count is displayed and simultaneously stored. Along with the counting system is a real time clock which gives the number of hours and minutes that elapse after the device has been set into operation. This time is also stored along with the count or displayed if required. A safety device is incorporated to prevent unauthorized user from operating the device. This is achieved by an in-built circuitry which prevents operation of the OCD until the required safety conditions are met by the user.

**The Sensor Bank:** The sensor bank is made up of more than one phototransistor, which can be activated by the application of either natural or artificial light. More than one sensor is used in order to avoid false counting. Pulses are generated whenever the incident light intensity on the phototransistors is obstructed. These pulses are generated to register the occurrence of a particular event (Figure 1). The generated pulses are combined with signals from the control unit and safety device in order to validate the count before it is recorded in the event counter.

**The event Counter:** The circuit for the event counter unit is as shown in Figure 2. The event counter consists of four, cascaded, decade asynchronous counter in order to be able to count to 10,000. Counting commences immediately, the validated count is used to trigger the first flip flop (ff) of the first decade counter. The output of the event counter is fed directly to a multiplexing unit as shown in Figure 3. Immediately the counting commences, an internal clock is activated in order to record the total time taken to count a given number of events. The timing sequence is achieved using a free running 555 timer and a divide by 12 binary counters, the combination of which produces a pulse every minute. These trains of pulses are counted to produce total elapsed time for counting a given number of events.

A timing reset facility is provided to allow the clock to be reset to zero at the beginning of a new counting operation. The outputs of the event and time counters are multiplexed using the circuit shown in Figure 2. However, control signals are used in operating the multiplexer, in order to differentiate the two outputs. The outputs of the multiplexer are made available to an LED display unit and to a memory storage unit. In other words, as the events are counted, the number of counts and time taken are automatically stored in the memory unit. The arrangement provides on-line display of current count, and a permanent storage of the total count and the elapsed time. By depressing appropriate button, a live time display could be obtained. Also depressing another button provides a memory recall. Consequently, display stored data (that is to say, the number of events counted and the time duration for the count). Data from the memory could only be read when the multiplexer unit is disabled, in order for the data on the data bus to be valid. This is achieved by connecting the memory READ/WRITE line to the buffer-disable line of the multiplexer unit. The memory unit is a non-volatile ram that is capable of keeping stored information for about 10 years.

**The Display Unit:** The display unit circuitry is as shown in Fig. 3. It is made up of the binary-to-decimal, decoders, seven segments LED display unit, and a circuitry to hold the data being displayed. The decoder when enabled decodes the input data into the corresponding code for the seven segment display; it also latches its input data, thereby holding the data, when the input lines are disabled.

### APPLICATIONS OF THE OPTICAL COUNTING DEVICES (OCD)

The OCD can be used as a general purpose device in counting discrete events in governmental, manufacturing and commercial establishments. A typical use in the factory may be in the determination of the number of goods produced over a period of time. For example, it can be used to determine the number of goods produced in a particular shift in the factory. This enables company management to monitor and control manufactured goods in the factory. The same information can then be used for "on the spot" management decision as regard plant raw material and energy optimal utilization.

### CONCLUSION

A general purpose, low cost optical counting device, with facility for permanent storage of total number of counted events has been developed in this study. The device can be operated using either a battery pack or normal electricity supply. In addition to event counting, the device has an in-built clock for recoding the total time duration of counting a given number of discrete event. Also provided are security switches to prevent unauthorised operation of the device. The device as developed is capable of usage in manufacturing, governmental and commercial establishments.

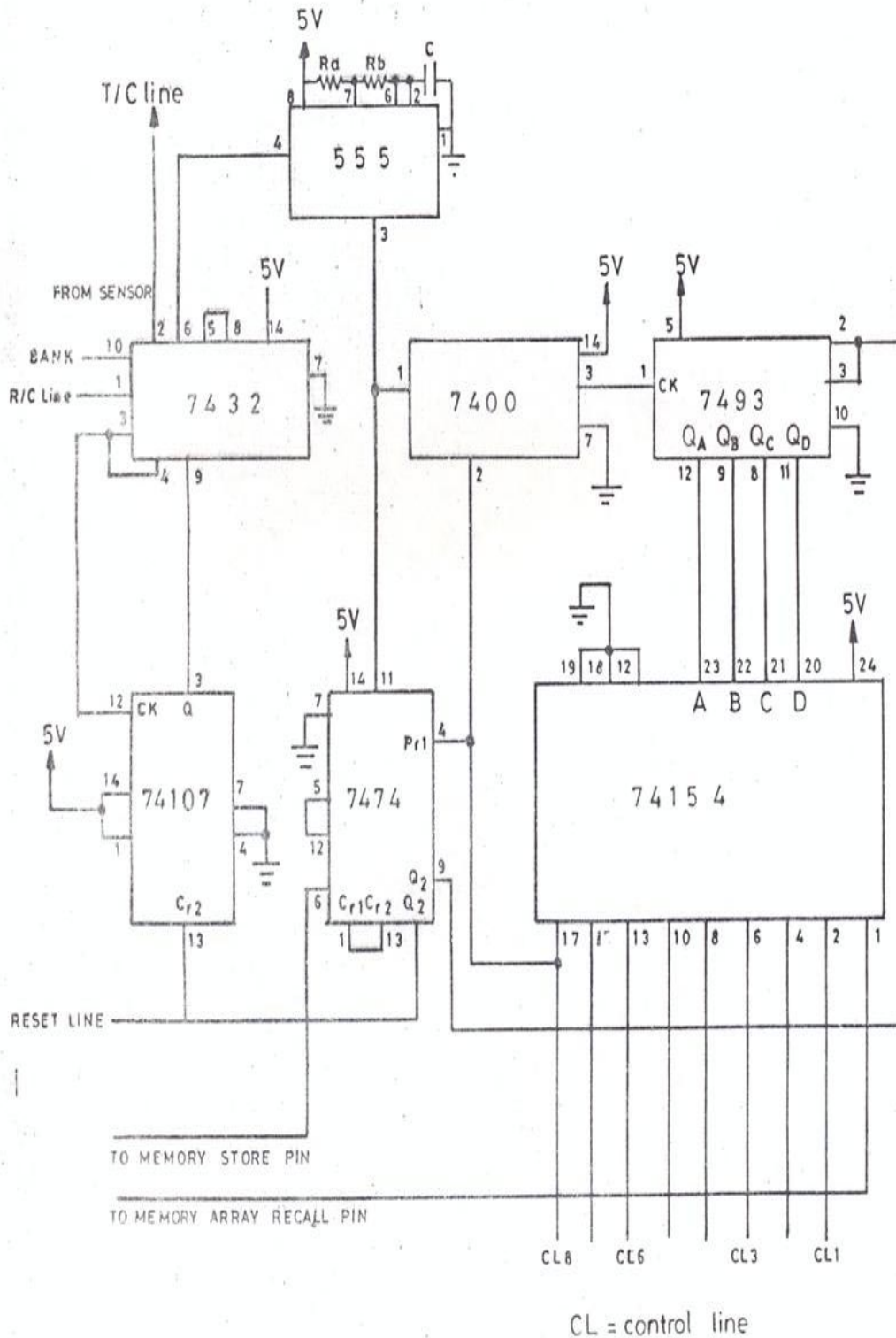

**Figure 1:** Circuit diagram for event counting and control unit

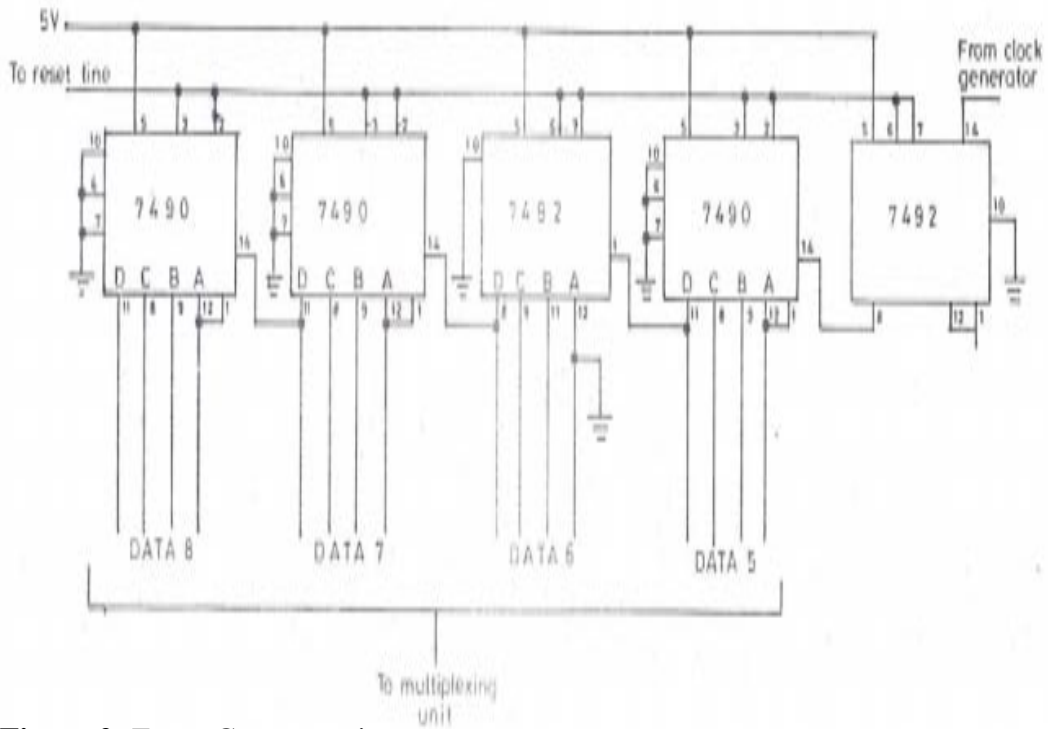

**Figure 2:** Event Counter unit

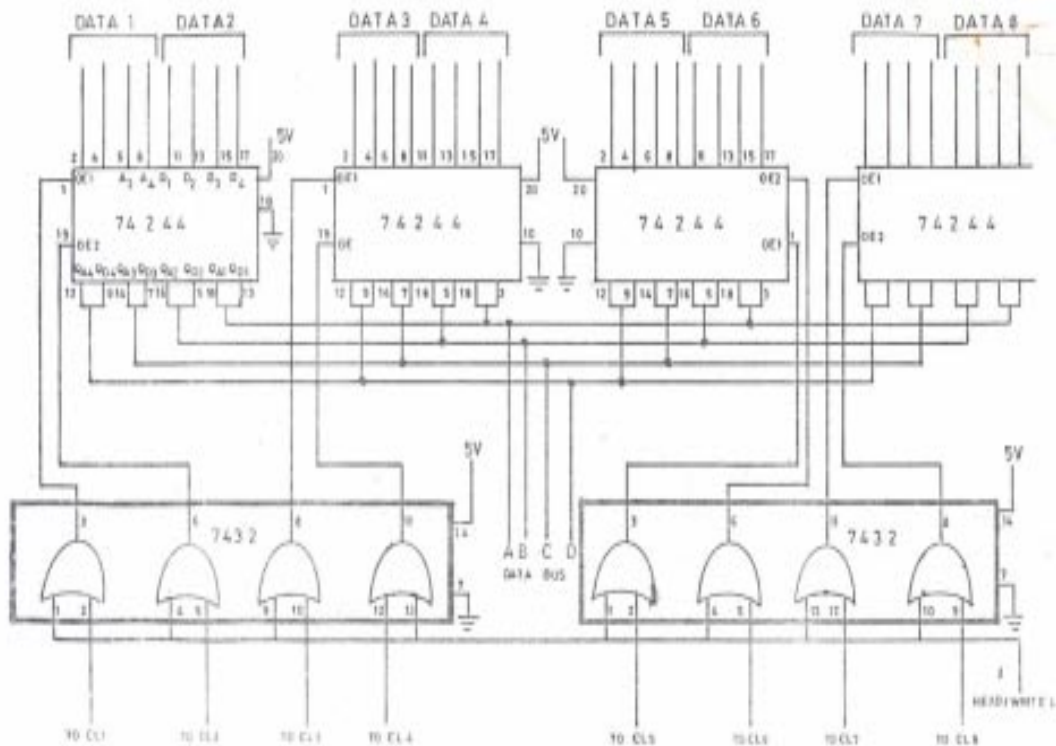

**Figure 3:** The Count Multiplexing and display unit

## REFERENCES

- Douglas, A. R.** (1979). Optoelectronics devices and Optical imaging techniques. pp. 43 - 47.
- John, R. H.** (1978). Sun Mankind's future source of energy. Proceedings of International Solar Energy Society Congress, p. 6.
- Stephen, R. E.** (1970). *Eletromechanics and Machines*. London: Chapman Hall.
- Thomas, L. F.** (1986). *Digital Fundamentals*. London: Charles E. Merril Publishing Company.